

Magnetic clutches and brakes

Precision Tork™ units provide constant torque independent of slip speed. They offer excellent overload and jam protection for all drive train components and also provide soft starts with zero slip when a preset torque is reached. Precision Tork permanent magnet clutches and brakes do not require maintenance and provide extremely long life.

Features and Benefits

Fast, precise torque adjustment

- Torque is set with a large knurled adjustment ring
- Infinite adjustability between minimum and maximum settings. This allows units to be fine tuned to your unique requirement.

Torque is constant with respect to speed

- By using the Precision Tork™ unit, you can solve almost any torque control problem
- Torque is extremely consistent and smooth at low, as well as high speeds

No external control or power source

- Simple to install
- Nothing to monitor
- Unaffected by power interruption or power fluctuation
- Safe to use

Dependable performance

- Smallest possible transition from static to dynamic torque
- Virtually eliminates the “stick-slip” phenomenon associated with friction devices
- Long life. The only wearing parts are the ball bearings
- Extremely accurate. Precision Tork™ units out-perform all other devices at low RPM

Versatile mounting: Easy to retrofit

- Clutches are available with hollow bores for mounting on motor shafts or jack shafts
- Bolt circles allow for fixed mounting, adding a pulley, or stub shaft adapters
- Brakes are available with solid shaft outputs

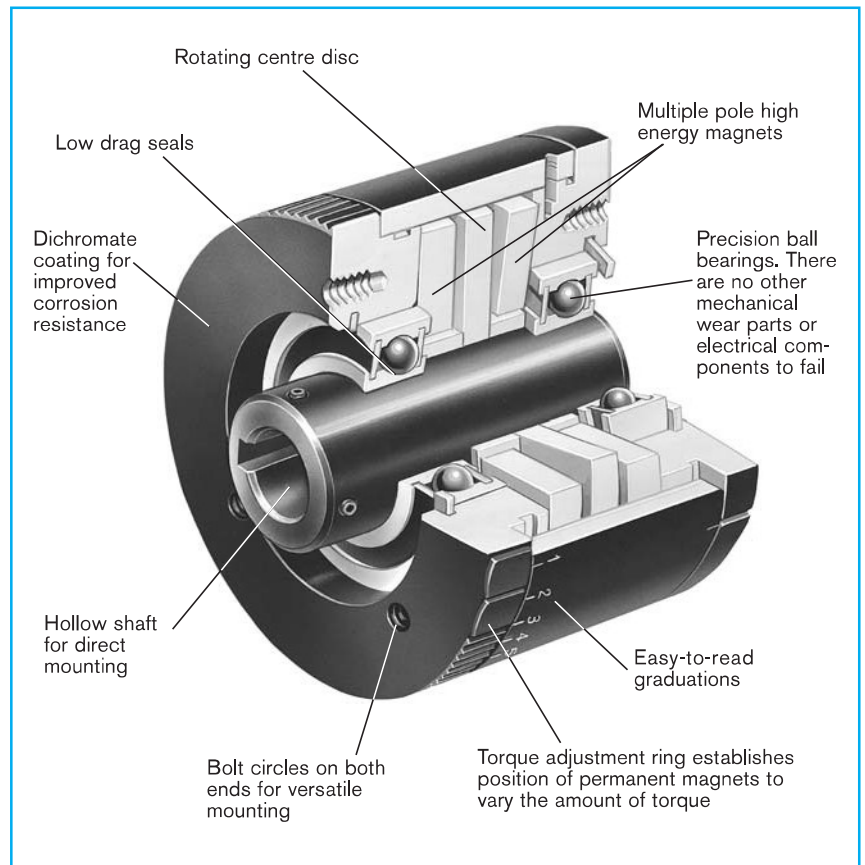

SPECIAL APPLICATIONS

Specials are our business. . .

- Special shaft bores and keyways
- Shaft extensions
- System retrofits
- Fixed torque units



Magnetic brakes - MB

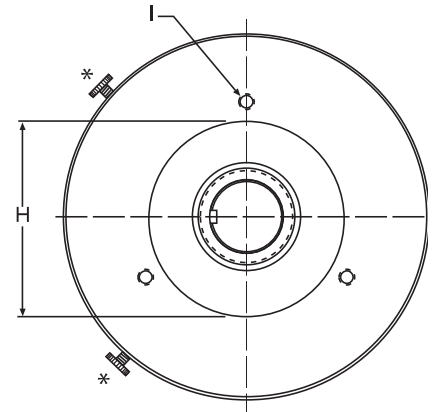
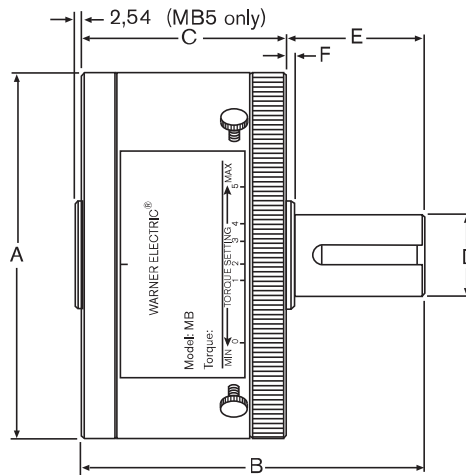

*Set screw adjustment

Drawing C

Specifications

Standard models	Stainless steel models	Max. torque (Nm)	Max. heat dissipation (W)	Inertia of output shaft (kgm ²)	Bending moment (Nm)	Max. speed (RPM)	Weight (kg)
MB1M-5	MB1MS-5	0,0078	3	$2,5 \times 10^{-7}$	0,11	3600	0,057
MB2M-6	MB2MS-6	0,16	10	$6,3 \times 10^{-6}$	0,56	3600	0,31
MB3M-8	MB3MS-8	0,68	18	$4,9 \times 10^{-5}$	1,13	1800	0,9
MB4M-14	MB4MS-14	1,24	22	$9,7 \times 10^{-5}$	1,13	1800	1,13
MB4M-15	MB4MS-15	1,24	22	$9,7 \times 10^{-5}$	1,13	1800	1,13
MB5M-19	MB5MS-19	3,4	72	$5,8 \times 10^{-4}$	2,82	1800	4,08
MB5M-24	MB5MS-24	3,4	72	$5,8 \times 10^{-4}$	2,82	1800	4,08
MB5,5M-19	MB5,5MS-19	5,6	110	$8,8 \times 10^{-4}$	2,82	1800	4,99
MB5,5M-24	MB5,5MS-24	5,6	110	$8,8 \times 10^{-4}$	2,82	1800	4,99
MB6M-19	MB6MS-19	7,9	150	$1,4 \times 10^{-3}$	2,82	1800	5,44
MB6M-24	MB6MS-24	7,9	150	$1,4 \times 10^{-3}$	2,82	1800	5,44
MB6DM-24	-	15,8	300	$2,5 \times 10^{-3}$	2,82	1800	11,37
MB9M-24	-	33,9	345	19×10^{-3}	5,65	1200	20,38

Dimensions (mm)

Models	Drawing	A	B	C	E	F	Pilot ø H
MB1M-5	C	25,1	34,8	21,59	13,2	-	10,01 - 10,06
MB2M-6	C	46,99	59,9	34,29	24,4	-	22,25 - 22,30
MB3M-8	C	69,6	76,71	50,2	26,5	0,76	35,08 - 35,13
MB4M-14	C	82,04	75,6	51,1	22,2	2,29	47,04 - 47,09
MB4M-15	C	82,04	75,6	51,1	22,2	2,29	47,04 - 47,09
MB5M-19	C	118,11	114	67	41,3	3,1	61,98 - 62,00
MB5M-24	C	118,11	114	67	41,3	3,1	61,98 - 62,00
MB5,5M-19	C	134,1	114,6	67,1	47,5	6,2	61,98 - 62,00
MB5,5M-24	C	134,1	114,6	67,1	47,5	6,2	61,98 - 62,00
MB6M-19	D	153,5	113,7	51,2	52,4	4,57	61,98 - 62,00
MB6M-24	D	153,5	113,7	51,2	52,4	4,57	61,98 - 62,00
MB6DM-24	**	**	**	**	**	**	82,50 - 82,55
MB9M-24	D	238,76	137,1	88,65	45,72	3,3	82,50 - 82,55

** Drawing on request

Magnetic brakes - MB

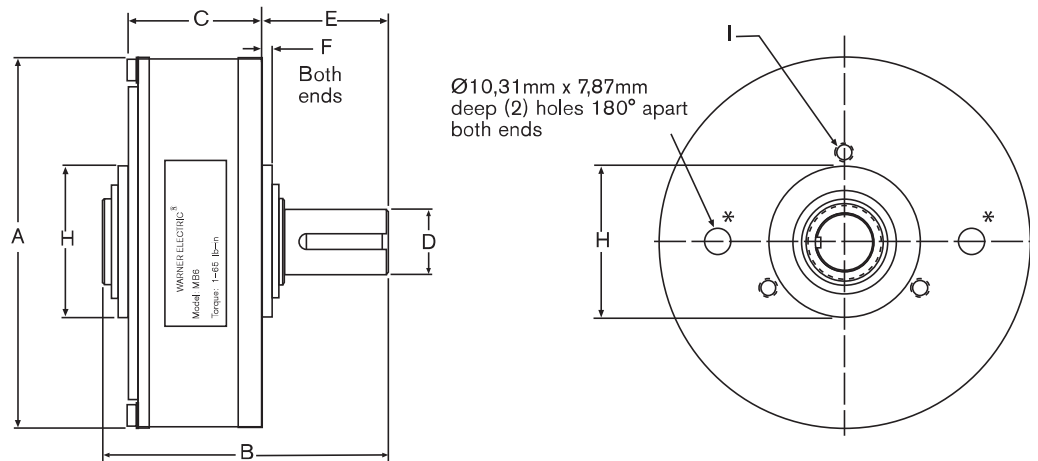

*Spanner wrench adjustment **Drawing D**

Dimensions (mm)

Models	Shaft ø D (h7)	Keyway - DIN 6885 Width x length)	Mounting (I)	Holes depth	Adjust screws
MB1M-5	5	4,5 Flat on 10,2	3 x M3 on ø 15,5 equidistant	6,4	M3
MB2M-6	6	5,5 Flat on 19	3 x M4 on ø 32 equidistant	8	M4
MB3M-8	8	7,5 Flat on 22,4	3 x M4 on ø 48 equidistant	11	M4
MB4M-14	14	5 x 19,3	3 x M5 on ø 60 equidistant	11	M4
MB4M-15	15	5 x 19,3	3 x M5 on ø 60 equidistant	11	M4
MB5M-19	19	6 x 25	3 x M6 on ø 80 equidistant	12,7	M5
MB5M-24	24	8 x 25	3 x M6 on ø 80 equidistant	12,7	M5
MB5.5M-19	19	6 x 25	3 x M6 on ø 100 equidistant	15,5	M5
MB5.5M-19	19	6 x 25	3 x M6 on ø 73,3 equidistant	12,7	M5
MB5.5M-24	24	8 x 25	3 x M6 on ø 100 equidistant	15,5	M5
MB5.5M-24	24	8 x 25	3 x M6 on ø 73,3 equidistant	12,7	M5
MB6M-19	19	6 x 25	3 x M6 on ø 100 equidistant	7,9	M5
MB6M-19	19	6 x 25	3 x M6 on ø 73,3 equidistant	7,9	M5
MB6M-24	24	8 x 25	3 x M6 on ø 100 equidistant	7,9	M5
MB6M-24	24	8 x 25	3 x M6 on ø 73,3 equidistant	7,9	M5
MB6DM-24	24	8 x 25	3 x M8 on ø 101,6 equidistant	13	Knob
MB9M-24	24	8 x 25	4 x M6 on ø 149,23 equidistant	12,7	M5
MB9M-24	24	8 x 25	3 x M6 on ø 107,95 equidistant	12,7	M5

Magnetic clutches and brakes

Heat Dissipation Charts

 Intermittent operation (50 % duty cycle)

 Continuous operation

MB1

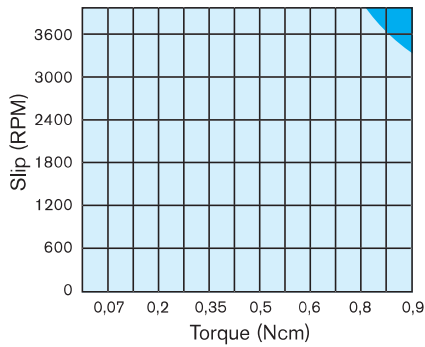

MC1.5/MB1.5

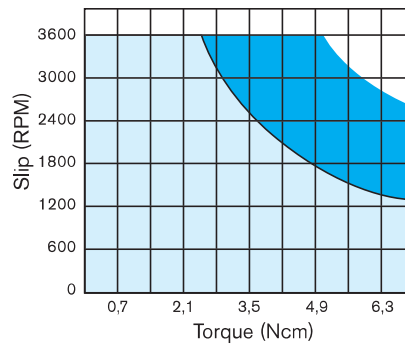

MC2/MB2

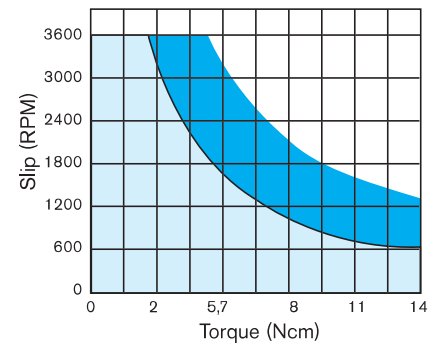

MC3/MB3

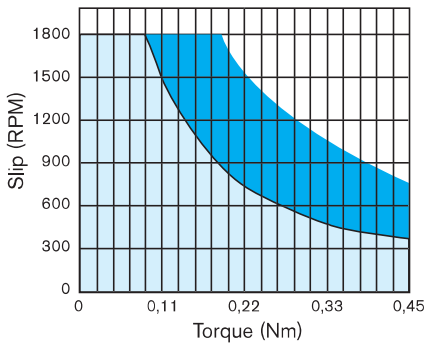

MC4/MB4

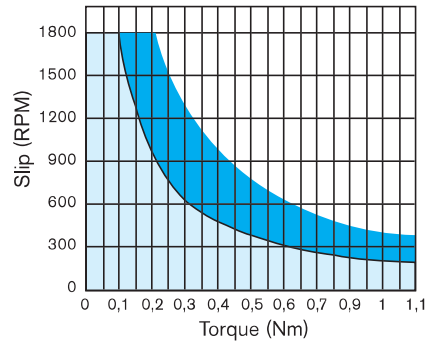

MC5/MB5

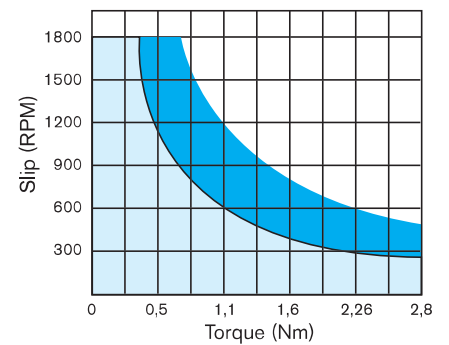

MC5.5/MB5.5

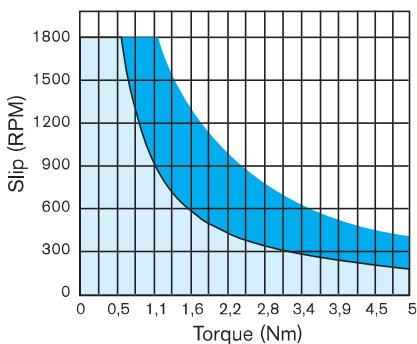

MC6/MB6

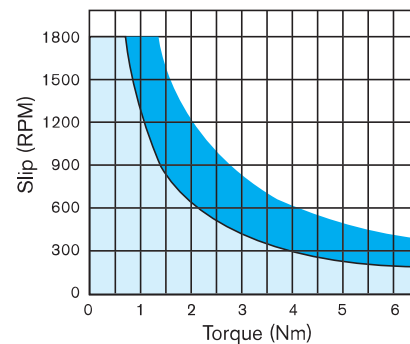

MC9/MB9

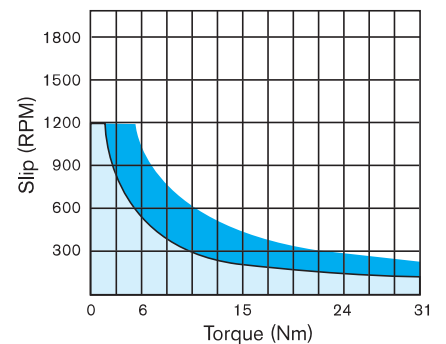

Magnetic clutches and brakes

Torque Setting Charts

MB1

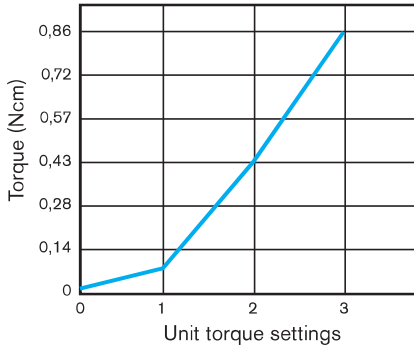

MC2/MB2

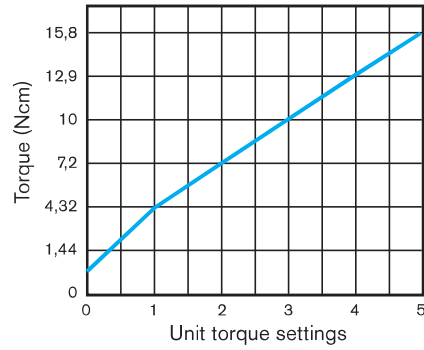

MC3/MB3

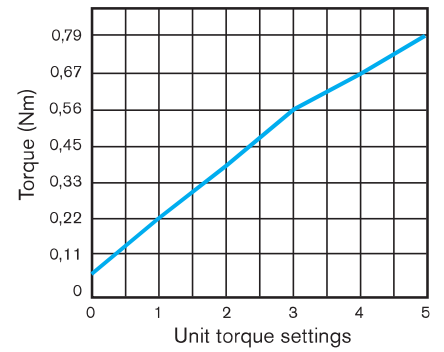

MC4/MB4

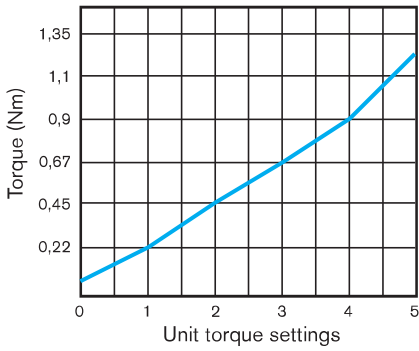

MC5/MB5

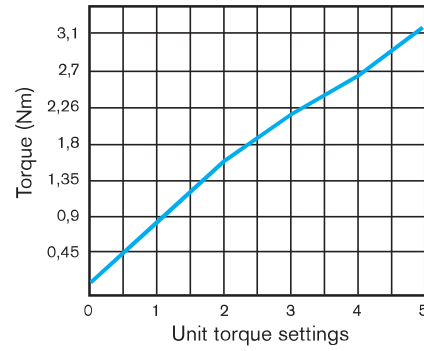

MC5.5/MB5.5

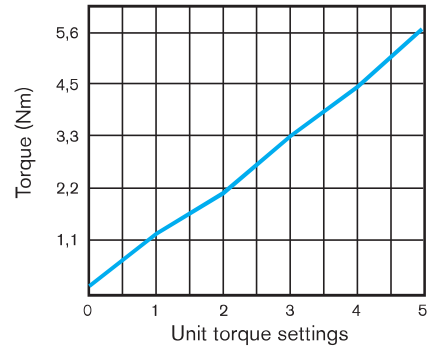

MC6/MB6

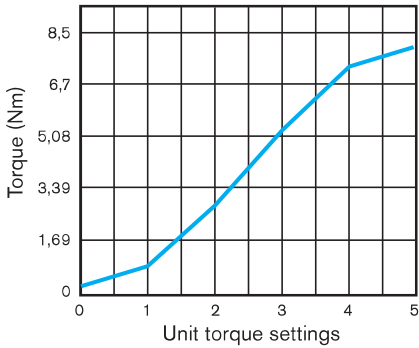

MC9/MB9

